

**Vogel Laboratorium**

Schematic: Powerstage\_Multichannel\_CHANNEL\_TINY44\_2L+DK\_17

Sign: AV Date: 10.12.2013 22:03:13

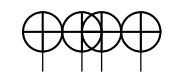
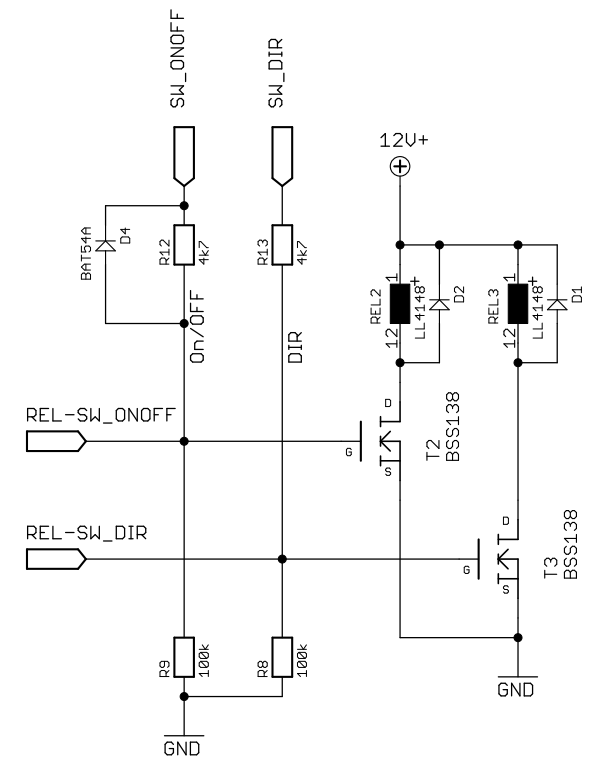
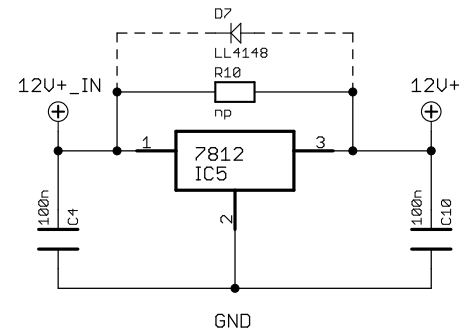
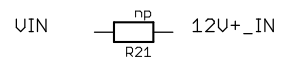
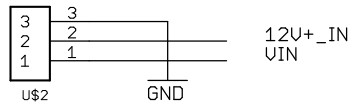
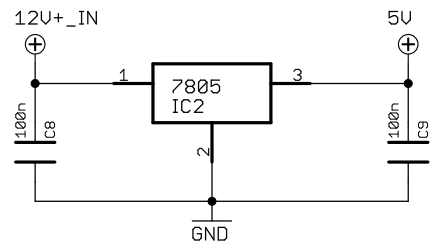
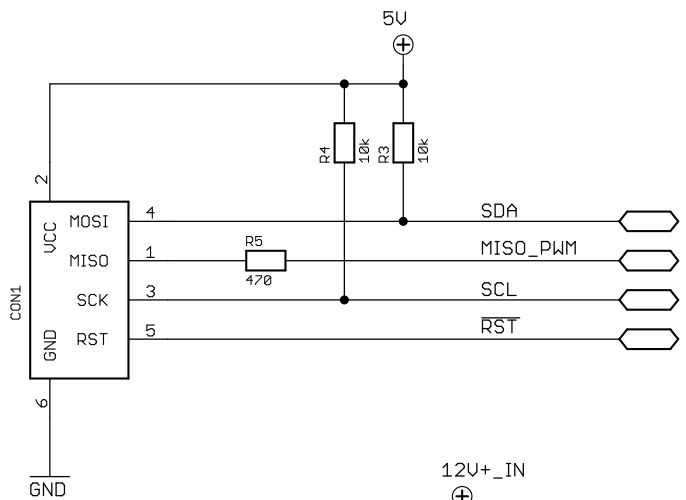

<b>Vogel Laboratorium</b>	
Schematic: Powerstage_Multichannel_CHANNEL_TINY44_2L+DK_17	
Sign: AV	Date: 10.12.2013 22:03:13

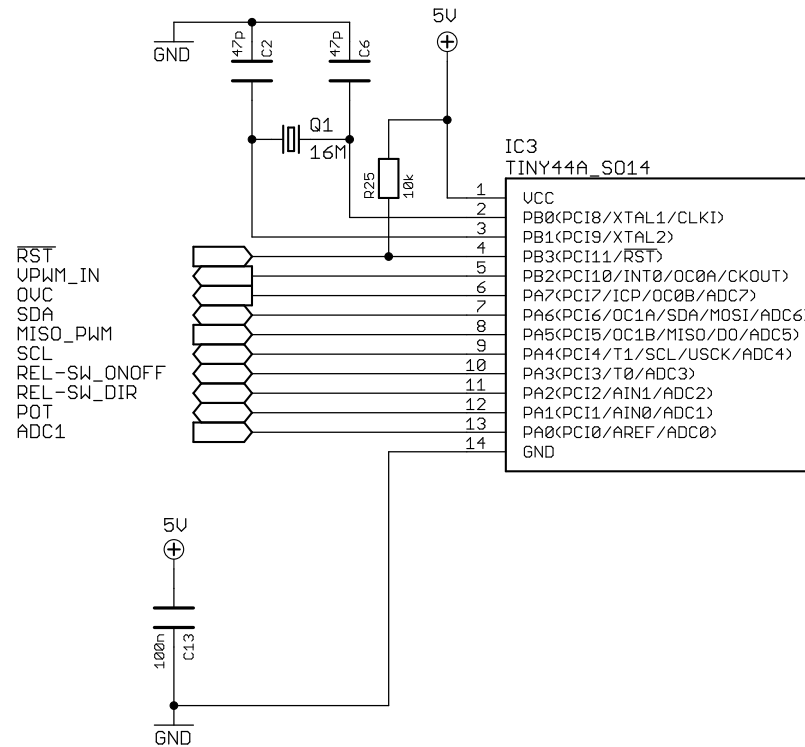
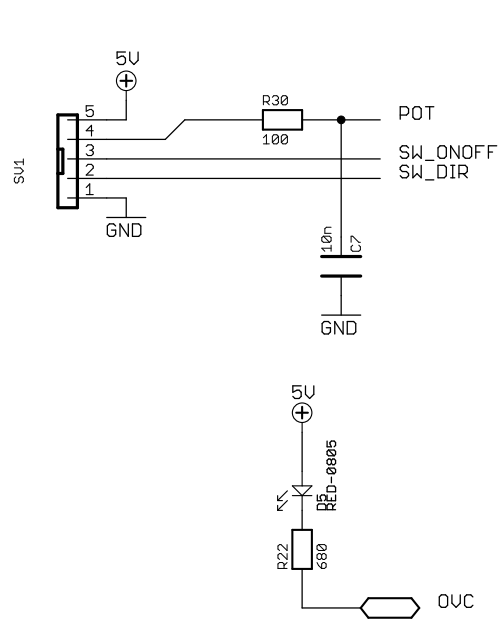

# Vogel Laboratorium

**Schematic:** Powerstage\_Multichannel\_CHANNEL\_3/TINY44\_2L+DK\_17

**Sign:** AV **Date:** 10.12.2013 22:03:13