

**Vogel Laboratorium**

Schematic: Powerstage\_Multichannel\_CHANNEL\_1\_T118Y44\_2L+DK\_16a

Sign: AV Date: 28.02.2013 23:45:21

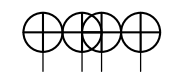
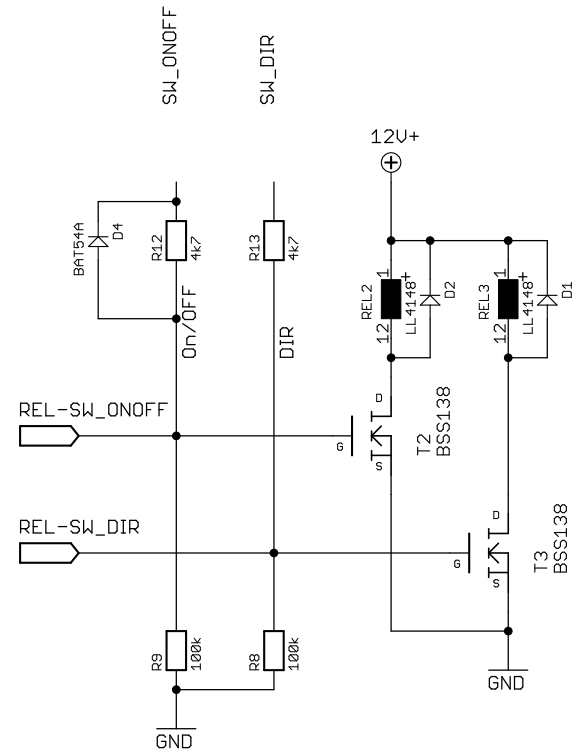
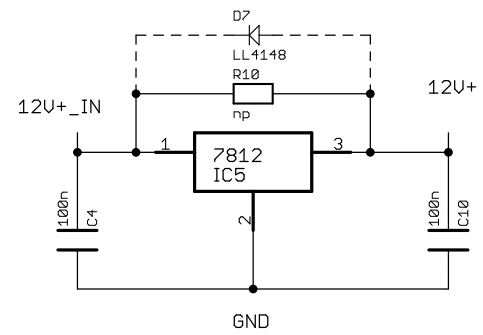
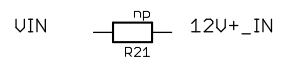
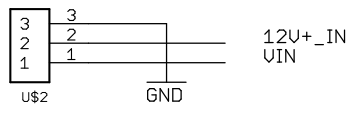
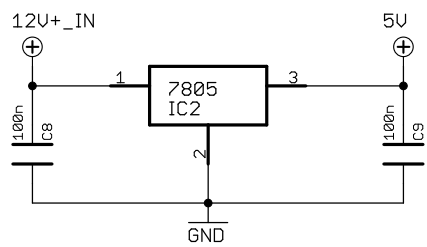
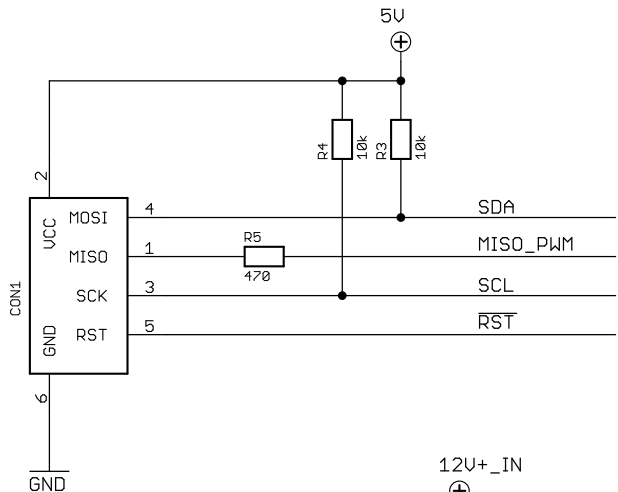

**Vogel Laboratorium**  
 Schematic: Powerstage\_Multichannel\_CHANNEL\_218Y44\_2L+DK\_16a  
 Sign: AV Date: 28.02.2013 23:45:21

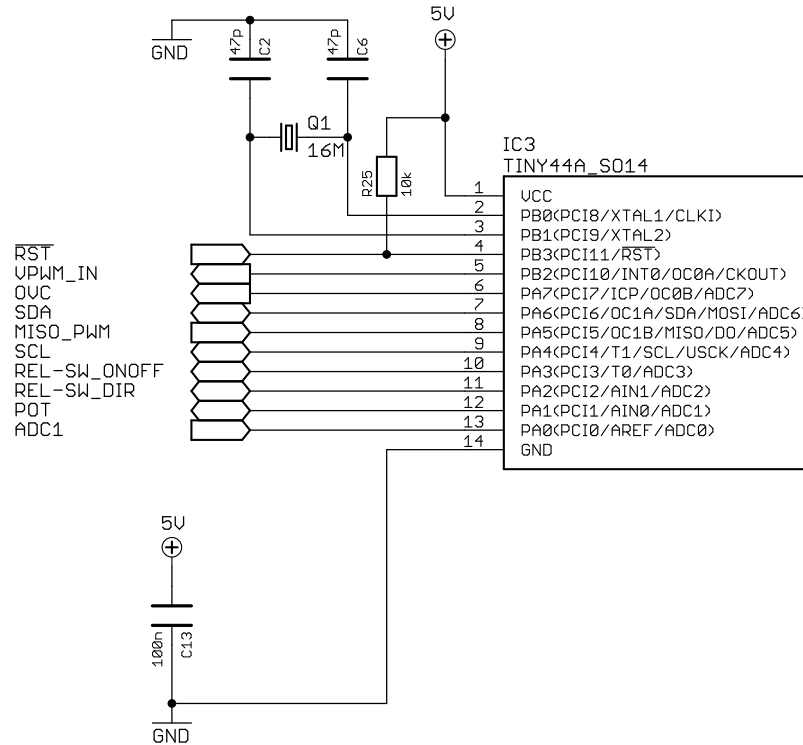
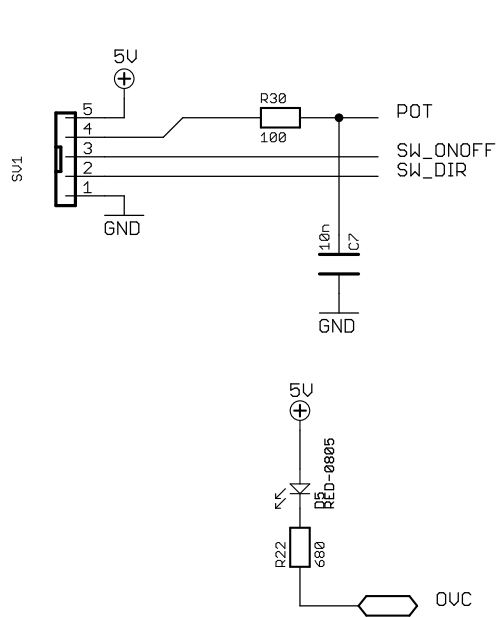

**Vogel Laboratorium**

**Schematic:** Powerstage\_Multichannel\_CHANNEL\_3/TINY44\_2L+DK\_16a

**Sign:** AV **Date:** 28.02.2013 23:45:21